

THE **CYPRUS**

OWNER'S MANUAL



CAUTION:

More than one GFCI used on the electrical circuit will render this spa inoperable.

This spa must be on a dedicated circuit.



STRONG SPAS™

Creating a lifestyle that lasts a lifetime.

P.O. Box 108
Northumberland, PA 17857
1-800-STRONG-9

1-800-787-6649

1/9/07

Table of Contents

Introduction	1
Safety Instructions.....	2
Installation Instructions.....	3
Electrical - General.....	4
Control Panel Identification.....	5
Start Up Preparations	6
Changing the Filter Cycles	7
Trouble Shooting.....	7 - 8
Spa Maintenance	9 - 10
Jets - Valves - Injectors - Suction.....	11
Warranties	12
Safety Precautions	13
Registration Card.....	13

**Be sure to locate the
Registration Form
at the back of this owner's manual.
Please fill it out and send it to
Strong Pools and Spas immediately.**

**Failure to return the registration card and a photocopy of the sales receipt within
30 days of purchase voids all warranties
provided by Strong Pools and Spas**

Introduction

Congratulations on your purchase of the finest, Rotational Molded resin whirlpool spa on the market today. We at Strong Pools & Spas are excited to assist your family in "Creating a Lifestyle that Lasts a Lifetime".

With proper care, operation and maintenance, your spa will provide your family many years of comfort and pleasure. Please take time to read all the instructions before you install your Strong Pools & Spa, "Cyprus" spa.

This manual explains safety precautions, installation instructions, operating directions and maintenance procedures. If you have any questions after reading this manual, please call your dealer or Strong Pools & Spas service representative at 1-800-787-6649.

Read and understand all safety instructions, operating instructions and all warnings and cautions before adding water or attaching electrical power.

The Cyprus Spa

Please use this space to record the pertinent information about your new spa here:

Date of Purchase: ____/____/____

Color: _____

Serial #

Your Strong Spas Spa Serial Number is located on the Control Pack box panel.

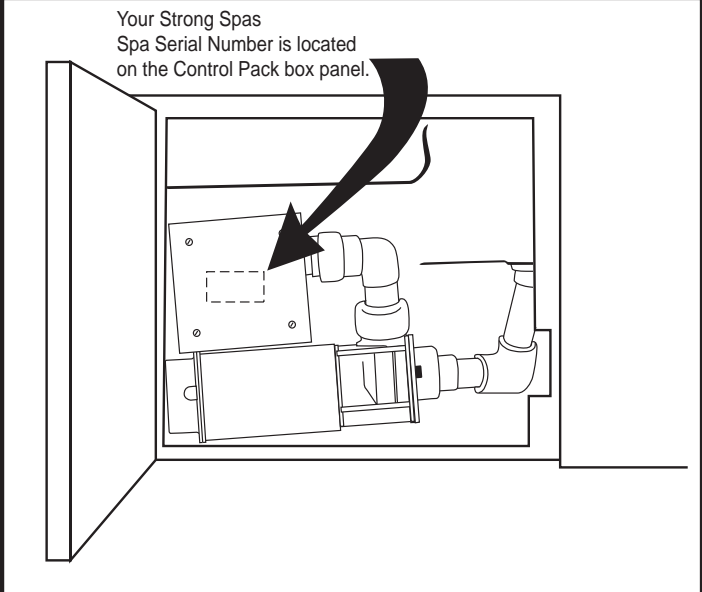

Important Safety Instructions

WARNING People with infectious diseases should not use a spa.

The use of alcohol, drugs or medication before or during spa use may lead to unconsciousness with the possibility of drowning.

Do Not use the spa immediately following strenuous exercise.

Persons suffering from heart disease, diabetes, high or low blood pressure or any other serious illness and pregnant women should consult with their physician before using the spa.

Excessive water temperature can be dangerous. Before entering the spa, the user should measure the water temperature with an accurate thermometer, since the tolerance of the water temperature regulating devices may vary as much as $\pm 3^{\circ}\text{C}$ (5°F). The Water should never exceed 40°C (104°F) and lower water temperature is recommended for extended use (exceeding 10-15 minutes) and for young children.

Long exposure at higher temperature can result in dizziness and/or hyperthermia. Hyperthermia occurs when the internal temperature of the body reaches a level several degrees above the normal body temperature of 98°F (36.7°C). The symptoms of hyperthermia include dizziness, fainting, drowsiness or lethargy.

The affects of hyperthermia include:

- Unawareness of impending hazard
- Failure to perceive heat
- Failure to recognize the need to exit the spa
- Physical inability to exit the spa
- Fetal damage in pregnant women
- Unconsciousness resulting in a danger of drowning

Children should be supervised at all times.

DO NOT OPERATE SPA WITHOUT CORRECT WATER LEVEL!

Keep the water level at least 2" over the top of the of the filter at all times. all jets must be under water. Use the ridge above the hydrotherapy jets as a guideline.

Actual features included in spa's descriptions and photos are subject to change without notice.

Installation Instructions

Spa Location:

Improper installation may result in equipment damage and will void the warranty. Your spa must be placed on a flat, level surface.

The space you choose to install your spa is a very important decision, you should consider all of the listed suggestions.

Check your local code office for understanding of building, fencing, gates, electrical, plumbing and enclosure required codes.

A location should be selected to compliment your lifestyle, the view from your house and the ability to supervise the spa.

Position the spa in relation to the surroundings of trees, sunlight exposure, wind, bathroom location, landscaping and evening lighting.

The spa with water is very heavy, if the spa is placed on flooring or decking, be sure the structure is strong enough to support the weight. The necessary support should be at least 75 pounds per square foot.

Install your spa, in a way that will allow easy access to the equipment door.

Storage area for maintenance equipment and chemicals (storing chemicals inside your spa cabinet will void the warranty)

Indoor Considerations:

All of the interior of the spa location must be able to withstand high humidity. The spa chemicals may have some corrosive effect.

Floor drain is needed to carry off splashed water from the spa.

It is strongly advised NOT to locate a spa on second story location that may be above finished living space.

Electrical - General Instructions

It is recommended that a licensed electrician install the power to your spa, in accordance with the National Electric Code or any local electrical codes in effect at the time of installation.

The circuit breaker must be dedicated and cannot be shared with any other appliances. It should be labeled and easily accessible to users. **DO NOT USE EXTENSION OR PLUG-TYPE CORDS OF ANY KIND.** The use of a shut-off box near the spa is recommended. Metal surfaces within 5 feet of the spa must be grounded to the spa.

A 120 Volt - 20 Amp GFI rated plug is furnished with the Cyprus Spa.

CAUTION: This spa will not work if more than one GFCI is used on the circuit. On 220 Volt applications, power supply must be hard wired into the power pack.

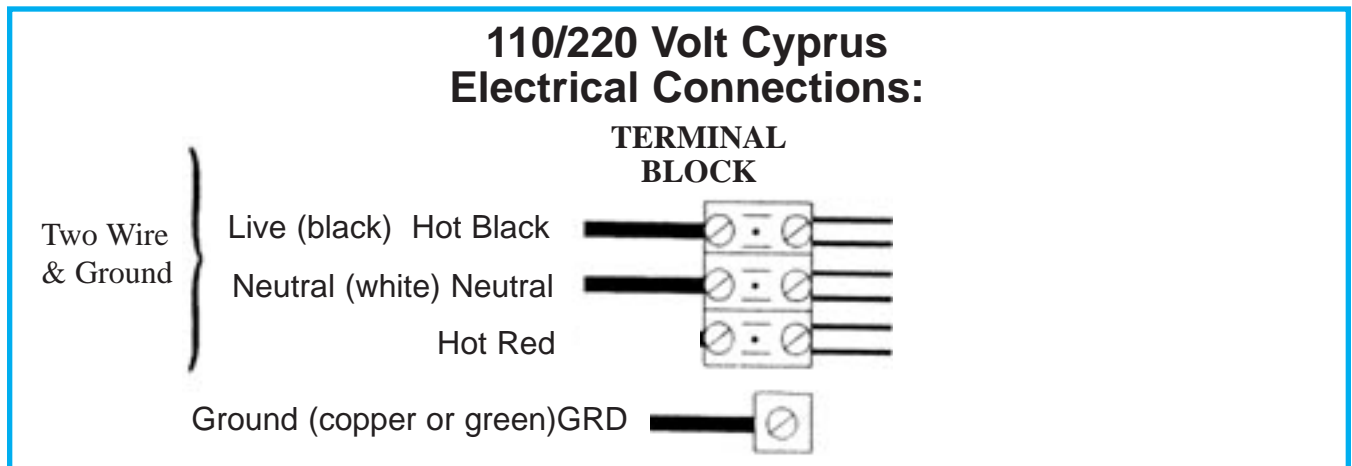

Note: Your Cyprus Spa's Heater can be converted to 220 Volts. The Spa's pump will remain 120 Volts.

This change must be performed by a certified electrician.

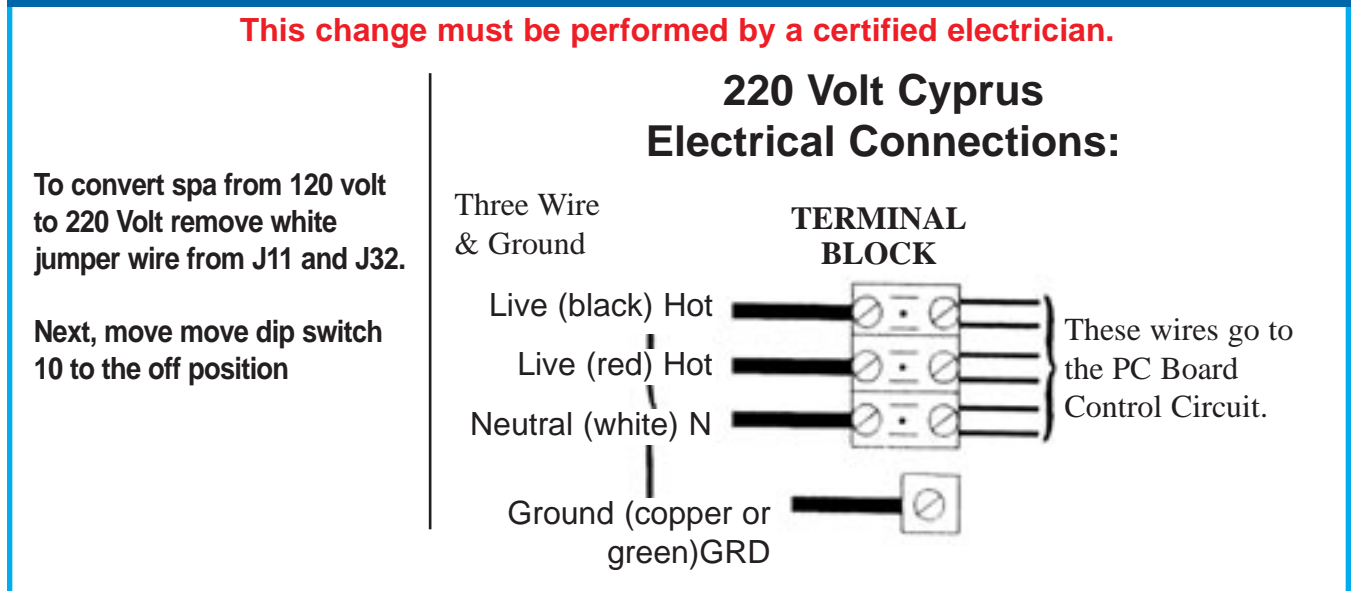

Connections should be made using copper conductors only. The connecting wire and circuit breakers or fuses must be sized to accommodate the total ampere load as specified on the equipment module data label.

Strong Pools and Spas only makes electrical recommendations, always consult a certified electrician.

Control Panel Identification



Jets

Touch the “Jets” button once to activate the low speed of the pump and again for the high speed. Press the “Jets” button again to turn off the pump. If left running, the low speed of the pump will automatically turn off after 4 hours, and the high speed will automatically turn off after 15 minutes. It may also activate for at least 2 minutes every 30 minutes to detect the spa temperature and then to heat to the set temperature if needed, depending upon mode. When the low speed turns on automatically, it cannot be deactivated from the panel; however, the high speed may be started.

Light

There are several color options in our spas and by pressing the light button in quick succession the customer can cycle through the different lighting options.

Temp ↑-↓

The start-up temperature is set at 100°F/37°C. The last measured temperature is constantly displayed on the LCD.

To display the set temperature, press the “Temp” button once.

To change the set temperature, press the temp up or temp down button before the LCD stops flashing. Each press of the “Temp” button will continue to either raise or lower the set temperature. After 3 seconds, the LCD will stop flashing and display the current temperature.

BEFORE START UP! IMPORTANT UNION ADJUSTMENTS

There are FOUR unions that may require hand tightening prior to operation of your spa. When filling the spa with water, keep observing these fittings for any slight water drips. If a drip is observed, just hand tighten until dripping ceases.

Startup Preparations

- Make sure that if spa is equipped with gate valves, that valves are opened. (Usually found in the Cyprus spas, these gate valves are easily noticed in your access area by the distinct “T” shaped handle.)
- When filling your spa remove the filter, and place hose into filter area. This will fill the plumbing first, and hopefully reduce the chance of air lock.
- Fill your spa at least 2” above top jets.
- Spa capacity: 216 gallons/818 liters

POWERING SPA

110 Volts - (Cyprus Classic Edition)

Spa must be on a dedicated line, meaning there are no other appliances on this circuit, and it will need a 20 amp GFCI breaker. (Strong Industries recommends that only one GFCI be present on the circuit, and that the owner follows any local building codes)

110/220 Volt conversion - (Cyprus Elite or Platinum Editions)

The Cyprus Elite edition requires a 35 amp GFCI breaker. (Strong Industries highly recommends a certified electrician performs the wiring of the spa.)

- Power up spa, Controls will read the program # (r59), then 30 seconds top control should read “PUR”(This is setting was created in order to clear the pump of any air unwanted air in that area.)

A - Most spas do not require pump priming

B - Purge will clear lines of undesired air pockets

C - If pump makes inconsistent sounds, “cavitations”, then it will need primed (this can be done by loosening the unions)

- Top display will then read water temperature.

Due to the variations in spas and outside conditions, spas may take up to 24 hours to reach desired temperature.

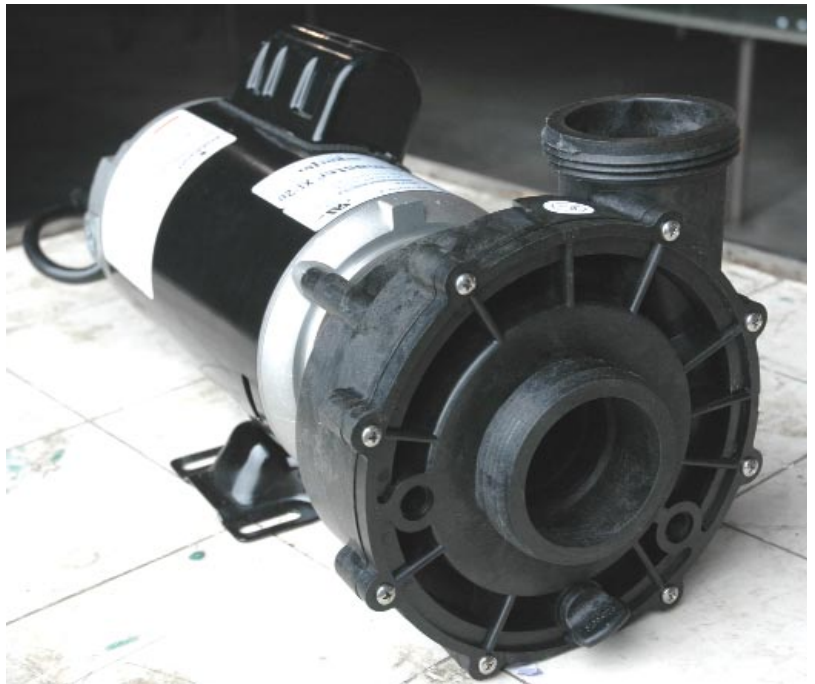

Changing Filter Cycles

FILTRATION

Proper filtration is an important key to maintaining the clarity of your spa's water. The filter system is designed for unsurpassed effectiveness at removing debris and suspensions from the water anytime the water is circulating.

Your control panel is set to filter for two hours every twelve hours. A two speed pump is supplied with your spa that provides filtration on low speed, the low speed will shut off if the temperature creeps more than 2 degrees above the set point, it will turn back on when temperature drops to the set point.

Filter Mode:

Press Aux and Heat same time, hold until C and #, it will scroll from C2 - C12 by holding

C2 = 2 hour filter cycle for every 12 hour period

C5 = 5 hour filter cycle for every 12 hour period

C12 = 12 hour filter cycle for every 12 hour period

Release at desired setting

Lower cost for less filter time, but cannot filter too much.

220 Volt Conversations (Cyprus Gold Edition):

Move white wire from inside of pump plug (large red plug on side of pack) and fasten alligator clip end onto J10.

Apply power and change programming to HC by calling technical support.

Troubleshooting

No power to spa:

1. Check for power at outlet
2. Check reset on GFCI cord (Press test then reset)
3. Check proper connection of cord to pack
4. Check fuse in pack (.5A 250 V UDL slow blow) the thicker wire of the two fuses.
5. Must have very good ground connection - If none call tech support

Trips Breaker:

1. Make sure dedicated line:
2. Check breaker
3. First take note to how long runs before trips

Trips instantly

1. Mis-wired - check electrical wiring
2. Breaker replacement - unhook to check
3. Short in Ozone - unhook to check - call tech support
4. Short in pump - unhook to check - call tech support

Trip after purge

1. Heater has short - check heater - call tech support
2. 110V spa set at HC, change program - call tech support

Poor Water Flow:

1. Clean filter
2. Check if adjustable jets (are all open)
3. May have air lock, prime pump by loosening top pump union.
4. If water diverted valves are present make sure they are all the way open.
5. If gate valves are present, make sure they are all the way open.
6. If none of this works possible line obstruction or impeller loose on pump drive shaft

No water or air flow to jet:

1. If adjustable jets, probably in off position. (At times can lock into position, may require some effort.)
2. Pinched line, cutting off flow before reaching spa.
3. Water diverter valve if present may be closed.

Air controls not working:

1. Remove cap on air valve, (with flat head screw driver) and make sure not broken or improper alignment.
2. If internals are broke, call tech support

Jets Only Have One Speed:

1. Check pump connection at pack make sure power off (red plug.)
2. Programming error, call Tech Support.
3. Button not working properly, call Tech Support

Light Not Working:

1. Check for proper connection on pack and in line at red alligator clips.
2. Check for proper connection at light.
3. Call Tech Support

Heat not working: (No blinking decimal in lower right corner of control display)

1. Check desired temperature is higher than current temperature.
2. Make sure Jets are on low speed
3. Aux must also be turned off.

Heat not working: (Blinking decimal, but no heat)

1. Give spa time to heat up and be sure to cover.
2. Bad heater, call tech support

Water temperature not close to displayed temperature:

1. Check thermister is located in thermalwell and insulated by rubber gasket.
2. Make sure that air vents are unobstructed.

LOC

1. Press Heat and Jets key simultaneously. This will activate and deactivate this code.

Display flashes "FLO" (FLOW)

1. This indicates that there is a water flow problem or defective pressure switch.
2. Make sure filters are clean
3. Check that service valves are open
4. Check for obstruction of flow
5. Adjust pressure switch (see pressure switch detail under description and use of controls)

Freeze Protect Over-ride FPO

This function is intended to be used on start-up after a fresh fill if water temp is below 52°F. The 6 hour duration of the FPO cycle is counted from the time the unit is powered-up and not from the time of its activation.

By pressing the Jets 1 and Light key simultaneously for 10 seconds, the freeze protect feature will be suspended for 6 hours. (the FPO will be activated) This is to allow the installer of the spa to check for normal operation if the spa is filled with water that is less than the set freeze protect level 52°F. FPO will appear every 10 seconds at the topside control. To manually go back to freeze protect mode, power down the system and re-boot. It is recommended that the system be left on low speed and heating in FPO mode.

Spa Maintenance

The maintenance and care of your spa is simple and easy to carry out, and if performed regularly as scheduled, problems will be minimal. It is important that the following procedures be read through and carried out on a regular basis for the best, long term, overall performance of your spa.

The filtering cycle of your spa should be operated at least two hours or more a day (whether or not the heater is heating) to remove impurities and to prevent disposition of contaminants in your spa. The filtering system works automatically. Keep the spa covered when not in use to reduce the loss of heat and to keep debris from settling in the water.

Maintaining the spa's proper water chemical balance is essential to the comfort and safety of the user. Water mineral content varies constantly and is directly affected by evaporation and the use of cleaning and maintenance chemicals, which will increase mineral content, when added. If the mineral content deviates from prescribed pH level (7.2-7.8) deposits on the spa walls, filter, electric heating element or gas heater manifold and piping may adversely affect the condition of your spa equipment.

Since the water capacity of your spa is far less than that of a swimming pool, the chemical reaction caused by the presence of one or more persons in the spa is more rapid and pronounced. In other words, it is much more difficult to maintain the proper pH balance in a spa than in a swimming pool. For these reasons, it is important to check frequently, the total alkalinity of the water, the pH level, and the sanitize level, then add prescribed chemicals as necessary to maintain the proper chemical balance. Failure to maintain a proper balance of chemicals in your spa will result in an early, premature failure of your spa parts including, but not limited to, the spa cover, piping, certain electrical components in the spa, electrical control box and topside panel, thus voiding the warranty.

ESSENTIAL CHEMICALS AND THERE USE

The following information on chemical use for spa maintenance is provided strictly as a guide for the spa owner and may or may not be appropriate to maintain your spa correctly and may, under certain conditions, be harmful to your spa and/or persons using the spa. Always check with your pool and spa dealer to determine which chemicals and/or procedures they recommend to maintain your spa correctly. STRONG POOLS and SPAS does hereby claim no responsibility or liability for use of and quantities of the chemicals listed.

Spa Maintenance

CONCENTRATED CHLORINATING GRANULES - The minimum chlorine level in the spa should be at least 2PPM (parts per million). Chlorine level should be tested frequently and the chemical added to maintain a safe level of 2PPM. This type of chemical can be added in quantities of 0.5 ounce per 500 gallons of spa water. Check the chlorine level at least seven hours or more after adding to determine the full effect of the added chemical. Liquid chlorine is not recommended.

ORGANIC POLYMERS - are used in various forms. These chemicals clear up cloudy or dirty water appearance and prevent calcium deposits on the inside spa finish, plumbing and heating equipment. Use as recommended by the manufacturer.

METAL GON - or its equivalent is a chemical that will prevent iron in the spa water from staining the spa finish. This chemical is added to the spa water when the spa is filled for the first time or when refilled. Use as recommended by the manufacturer.

SILICONE EMULSION - quickly and effectively disperses foam and is completely compatible with the other chemicals listed. Use as recommended by the manufacturer.

SPA WATER - should be changed periodically, depending upon frequency of use and other conditions that may affect water suitability. Typically 60 to 90 days is a satisfactory interval under normal conditions. With heavy usage, the interval between water changing should be less.

SPA FILTER CARTRIDGE - should be cleaned every 2 to 4 weeks depending on the frequency of use. Rinse the filter cartridge with a pressure hose and re-install filter cartridge in the filter housing. When changing spa water it is good practice to soak the filter cartridge in filter cleaner. The filter cleaner is specially made to remove accumulation of oils and other contaminants which will ensure good, sanitary water and extended filter cartridge life.

ADDING CHEMICALS - to your spa water: Add to the center of the spa with the pump and the air blower (bubbles) operating simultaneously. Make sure the water is heated. Never add chemicals to cold water, as this will effect chemical action. Also, never add chemicals directly into the skimmer.

Store all chemicals in a cool, dry place and in such a way as to prevent children and pets from contacting.

WINTERIZING

Before draining, power must be turned off at the GFCI circuit breaker. Attach a garden hose to the faucet and open it. Water will start to drain. You can use the water to water the garden. You can also siphon the water from the spa. The drain faucet will not remove all the water. You may have to remove a small amount of water by hand, using a towel. You must also use a wet-vac to remove the water from the lines by suction and/or blowing. Water left in the line and jets might freeze and damage them. To adequately clean out the lines, place the wet-vac over each jet face for 10-15 seconds. Remove the filter cartridge and do the same to the filter cavity. also, let the water drain from the heater tube by loosening the black split nuts on each side of the heater tube. Remember to retighten the split-nuts when completed. Use the wet-vac to vacuum up any water that may have drained on the spa floor area.

Note: Damage caused by improper winterizing will not be covered under warranty. You may want to contact a professional for proper winterizing.

Jets, Valves, Injection and Suction



Directional Jet 3"
Center Pivots

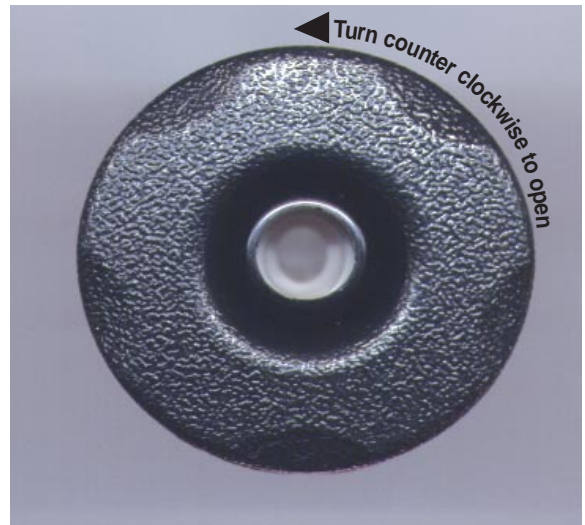

Directional Jet 2"
Center Pivots



Top Air Control Valve
(Air Control Valve should be turned off when spa is not in use. The spa will heat up faster.)



Bottom Suction



STRONG SPAS

Creating a lifestyle that lasts a lifetime.

WARRANTIES

Shell: Lifetime

Plumbing: 1 year

Strong Spas warrants the original retail purchaser the integrity of the spas plumbing against leaks as a result of defects in material or workmanship for a period of 1 years. (parts and labor) Stainless jets - all jets must be kept under water.

Equipment: 1 year

Strong Spas warrants the original retail purchaser the integrity of the spas Equipment Pack (pumps, heater, control system) to be free from defects in material and workmanship for a period of 1 year from the date of the original retail purchase. (parts and labor)

Warranty Specifics

Ozonators - Strong Spas warrants the original retail purchaser that the factory installed ozonators will not malfunction due to defects in workmanship for a period of 1 year from the date of the original retail purchase.

LED Lighting - Strong Spas warrants the original retail purchaser that the factory installed LED Lighting System will have a 1 year warranty to be free from defects in workmanship and materials from the date of the original retail purchase.

Exclusions

- This limited warranty is enforceable only by the original retail purchaser. Fuses, covers, light bulbs, light lenses, spa pillows, seals on pumps and motors, and any dealer installed accessories are specifically excluded from this limited warranty.
- All warranties are null and void if any of the following occur:
 - the spa has been subject to alteration, neglect, misuse or abuse.
 - any damages caused by failure to install, maintain, and operate the spa in accordance with the recommendations contained in Strong Spas Owners Manual.
 - any and all costs of spas removal and replacement including but not limited to removal and transportation, damages to landscaping, house structures.
 - the spa has been used in a non-residential application or an application in which it was not designed.
 - spa shell damage caused by excessive heat build-up due to failure to cover the spa while empty of water and/or exposure to direct sunlight.
 - any damages caused by improper maintenance of spa water chemistry or by any undissolved spa chemicals which may cause bleaching of the spa shell and erosion or discoloration of stainless jets.
 - any repairs that are done by any one other than authorized Strong Spas agent, or anyone without expressed written permission by Strong Spas warranty department.

DISCLAIMERS

ALL IMPLIED WARRANTIES ARE NULL AND VOID IF THE RETAIL PURCHASER FAILS TO RETURN THE SPAS WARRANTY CARD BACK TO THE MANUFACTURER SUPPLIED WARRANTY ADDRESS WITHIN 30 DAYS FROM DATE OR PURCHASE.

STRONG SPAS AND ITS AUTHORIZED AGENTS SHALL NOT BE LIABLE FOR ANY INJURY, LOSS, COST OR OTHER DAMAGE, WHETHER INCIDENTAL, CONSEQUENTIAL, SPECIAL OR PUNITIVE, ARISING OUT OF ANY DEFECT COVERED BY THIS LIMITED WARRANTY, INCLUDING WITHOUT LIMITATION, LOSS OF USE OF THE SPA AND COST FOR REMOVAL OF DEFECTIVE PRODUCT, EVEN IF STRONG SPAS HAS BEEN ADVISED OF THE POSSIBILITY OF SUCH DAMAGE, THE LIABILITY OF STRONG SPAS UNDER THIS LIMITED WARRANTY, IF ANY, SHALL NOT EXCEED THE ORIGINAL AMOUNT PAID FOR THE DEFECTIVE PRODUCT. COVERAGE UNDER THIS LIMITED WARRANTY SHALL COMMENCE AS OF THE ORIGINAL DATE OF PURCHASE AND THE DURATION OF SUCH COVERAGE SHALL NOT EXTEND FOR ANY REASON WHATSOEVER BEYOND THE STATED TIME PERIOD. THESE DISCLAIMERS SHALL BE EQUALLY APPLICABLE TO ANY SERVICE PROVIDED BY STRONG SPAS OR ITS AUTHORIZED AGENTS.

LIMITATIONS

THIS LIMITED WARRANTY IS NON-TRANSFERRABLE AND ONLY APPLIES TO THE ORIGINAL PURCHASER. THIS LIMITED WARRANTY SUPERCEDES THE PLACE OF ALL OTHER WARRANTIES EXPRESSED OR IMPLIED, IN FACT OR AT LAW, INCLUDING IMPLIED WARRANTIES OF FITNESS FOR A PARTICULAR PURPOSE. ALL WARRANTY SERVICE MUST BE AUTHORIZED BY STRONG SPAS AND PERFORMED BY ITS AUTHORIZED AGENT. NO DEALER, DISTRIBUTOR, SERVICE COMPANY, OR OTHER PARTY IS AUTHORIZED TO CHANGE, MODIFY, OR EXTEND THE TERMS OF THIS LIMITED WARRANTY IN ANY MANNER WHATSOEVER.

For current update changes on warranties, consult our website at www.strongspas.com

Points on Spa Safety for Strong Spas Spa Owners

SAFETY PRECAUTIONS / DANGER - RISK OF INJURY

1. Please use the Hot Tub when others are present.
2. Children should be supervised at all times.
3. To avoid the risk of drowning, keep the filter clean and unclogged. Do not remove the suction drain cover. Do not modify the suction or filtration systems.
4. Exercise caution when entering or leaving the Hot Tub. When changing positions, be sure of your footing before applying your full weight as water refraction can be misleading.
5. Do not stay in the water for extended periods of time. Set reasonable time limits. Leave the Hot Tub, cool down, take a shower, relax, then return for another stay.

FOR YOUR RECORDS:

For future use, it is advisable that you write down some information pertaining to the model of the spa you have purchased. If you are unsure of the model name, frame size, etc., contact your dealer immediately to acquire the information needed. When making a warranty claim or just purchasing replacement parts, it is necessary to know the following information.

PURCHASE DATE: _____

MODEL NAME: _____

SERIAL NUMBER: _____

SHELL COLOR: _____

**Failure to return this registration card and a photocopy of the sales receipt within
30 days of purchase voids all warranties
provided by Strong Pools and Spas**

REGISTRATION CARD

I have read and fully understand the warranties given to me by **STRONG POOLS & SPAS** and have assembled my spa in accordance with **THIS INSTRUCTION BOOKLET**. Furthermore, I have read the **POINTS ON SPA SAFETY** at the top of this warranty card. I am returning this card and a copy of my sales receipt to you, signed by me, in order to register my spa in accordance with your warranties, within 30 days of purchase.

Purchaser's Name: _____ Purchase Date: _____

Address: _____ Model Name: _____

City, State, Zip: _____ Serial Number: _____

Telephone No.: _____ Dealer's Name: _____

Address: _____

Signature: _____

Comments: _____

RETAIN THIS BOOKLET FOR FUTURE REFERENCE:

FOR ANY MISSING PARTS, PROBLEMS OR QUESTIONS CALL:

MONDAY THROUGH FRIDAY 8:30 AM - 5:00 PM E.S.T.

(570) 275-2700

- GIVE YOUR NAME
- TELEPHONE NUMBER (AREA CODE)
- NAME OF SPA
- NAME OF MODEL
- QUANTITY AND TYPE OF PARTS
- REASON FOR REQUEST
 - A. DAMAGED
 - B. DEFECTIVE

PLACE
STAMP
HERE

STRONG POOLS & SPAS

3204 Point Township Drive (Rte. 11)

P.O. Box 108

Northumberland PA 17857 USA